



The influence of water field capacity and fertilizer combinations on tomato under intelligent drip in greenhouse

Shaikh Abdullah Al Mamun Hossain^{1,2*}, Lixue Wang², Liu Haisheng², Wei Chen³

¹ Department of Agricultural Engineering, Patuakhali Science and Technology University, Bangladesh

² College of Water Conservancy, Shenyang Agricultural University, China

³ Research Institute of Water Resources and Hydro-power, Shenyang, China

ARTICLE INFO

Keywords:

Control weather
Potash
Smart drip system
Urea
Vegetables fruits

Article history

Submitted: 2022-01-10

Accepted: 2022-04-09

Available online: 2022-05-26

Published regularly: June 2022

* Corresponding Author

Email address:

saamamunhossain@pstu.ac.bd

ABSTRACT

Tomato production is significant as the demand is increasing in time to meet food security and human nutrition as well. The purpose of the study was to investigate the effect of water and fertilizer application in greenhouse tomato growth index, yield and quality using an intelligent drip system to achieve improved yield by minimizing the fertigation. A randomized block design was used in ten treatments including control (CK-W₄N₄K₄) consisting four level (W₁-65%, W₂-75%, W₃-85%, W₄-100%) each of water field capacity and four-level Urea-Potash (N₁,K₁-245,490, N₂,K₂-350,700, N₃,K₃-455,910, N₄,K₄-80,100 kg ha⁻¹) combinations. Data obtained were analyzed by a general linear model and developed a regression model for yield. The results showed, the highest tomato yield was 103.16 t ha⁻¹ in T₈-W₃N₂K₁ significantly influenced by the treatment, which is found 2% greater compared to the CK (100.92 t ha⁻¹). The highest leaf area index (5.21) was obtained with T₇-W₃N₁K₃ produced improved yield. The highest fruit weight (288.77 g fruit⁻¹) and fruit diameter (85.33 mm) obtained with T₂-W₁N₂K₂ had no significant influence on tomato yield. The model delivered a paramount prediction (r² = 0.82) of tomato yield. In conclusion, results showed the intelligent drip system could be used to minimize inputs to improve tomato production.

How to Cite: Mamun Hossain, S.A.A., Wang, L., Haisheng, L., Chen, W. (2022). The influence of water field capacity and fertilizer combinations on tomato under intelligent drip in greenhouse. *Sains Tanah Journal of Soil Science and Agroclimatology*, 19(1): 80-90. <https://dx.doi.org/10.20961/stjssa.v19i1.58328>

1. INTRODUCTION

Agricultural production is geared by enormous food and nutritional demand. As agricultural production is a function of various input and management services, thus the application of technological support has improved the production significantly. Irrigation and nutrient supply by drip system are considered to be two vital inputs that could influenced to crop growth and improve yield (Wang & Xing, 2017; Zhu et al., 2012).

Tomato (*Solanum lycopersicum*) is a worldwide popular and valuable vegetable for its taste and dietary values in everyday life. Greenhouse tomato has become a major vegetable for the areas of long winter and extremely hot weather, which could meet up the year-round demand through its high yielding potential and economic benefit (Chen et al., 2013). This day, most of the researchers, growers and customer satisfaction are focused on improving yield and good quality products. Many studies undertaken in

greenhouse tomato by a different regime of drip irrigation deployed emphasis on growth index (Alaoui et al., 2014; Patanè et al., 2011), fruits yield (Buttaro et al., 2015; Luvai et al., 2014; Wang & Xing, 2017; Xiukang & Yingying, 2016) and better quality (Alaoui et al., 2015; Chen et al., 2013) of tomato. Although irrigation is essential for influencing tomato yield nevertheless tomato cultivation by excess irrigation resulted water logging, water losses and creating salinity which affects on yield and quality. Excess irrigation cannot benefited due to inadequate yield with lack of quality and high cost of water application. On the other hand, the demand of water has been consistently increasing in areas other than agriculture which becoming at the cost of yield production. To accommodate the demand of the increasing world population agriculture is expected to improve its water utilization to meet extra 67% of food production from 2000 to 2030 year, in which water usage needs to be increase 14%

(FAO, 2017). This situation urges use of water saving methods for managing the consumer's future demand. As like tomatoes are one of the most vital year-round crops hence in greenhouse cultivation, it required high demand irrigation throughout the growing season. However, in water scarce area it is very much desired to conserve water for minimizing water application rather than improve yield. Accordingly, an appropriate irrigation system must be preferred for water savings as well as to improve tomato yield (Chen et al., 2013; Wang & Xing, 2017; Zhu et al., 2012). Presently in a rapid climate changing world as demand is increasing thus, greenhouse production with technological support is significantly growing (Mamun Hossain et al., 2018). Therefore, it is immensely important to develop a greenhouse tomato production system using intelligent drip irrigation that could attain tomato growth index towards improved yield and quality.

Drip irrigation methods become inefficient due to various arduous and time-consuming process. Currently, this method is being used broadly for crop production both in field and greenhouses condition (Van Opstal et al., 2021). Now people are moving towards a more efficient and sophisticated water management process. Various methods have been used to accomplish water saving application in crops such as tomato, which ranges from fundamental ones to more technically advanced methods. Many researchers have made drip irrigation scheduling based on crop water requirements (Biswas et al., 2015; Mamun Hossain et al., 2018), crop water stress index using tensiometer (Buttaro et al., 2015), evaporation pan method (Senyigit et al., 2011) etc. Therefore, it is necessary to determine how much water is required to irrigate and when to irrigate for specific crops using weather and crop related parameters, thus strenuous. But implementation and decision making calculation of irrigation scheduling for farmers are not practicable. In this regard, scientists are changing their traditional thinking of irrigation scheduling with an advanced technological tactics which are sensor-based automatic systems based on soil moisture content at specific time with a specific duration under a pressurized way.

Several studies were carried out in the field condition (Appasaheb et al., 2015; Kishore & Chaitanya, 2014) for different crops using intelligent drip irrigation method. But the researchers are unaware about the intelligent irrigation practice in greenhouse tomato production. Some scientists practiced tomato cultivation either by applying simple nitrogen or nitrogen & phosphate or with plane NPK using non-intelligent irrigation method (Zhai et al., 2015). However, the water and fertilizer application under intelligent drip system for greenhouse tomato production is remain unnoticed. Therefore the current research has been conducted to minimize the use of water and fertilizer for better growth index, to improve the yield and physical quality of tomato by intelligent drip irrigation system in the greenhouse.

2. MATERIAL AND METHODS

2.1. Experimental site

The experiment was conducted in a greenhouse of Water Conservancy Research Institute, Liaoning Province, China

during February-July, 2017. The location of the institute is 123° 31' East longitude and 42° 09' North latitude. The area has a temperate continental monsoon climate with short warm rainy summer, long cold winter with snow and short windy spring. The temperature has a declining trend from early November and coldest in December through February and then it goes up from April. The annual mean temperature is 6.63°C. Annual total precipitation and average relative humidity are 507.23 mm and 67.43%, respectively. The yearly sunshine duration is between 2520 to 2750 hours and the sunshine duration percentage is 60.1%. The soil type inside the greenhouse is clay-loam with 24% water field capacity and 1.65 g cm⁻³ bulk density. The greenhouse used for the experiment was a single-slope, energy-efficient modern solar greenhouse. The greenhouse was built with 86 m long, 9.94 m span width and 4.5 m height, covered by 500 µm transparent polyethylene film and equipped without a heating and ventilation system. The tomato growth is correlated with the greenhouse's microclimate in which the average temperature and humidity of the entire cropping period were 21.22 °C and 69.96% respectively. The monthly average meteorological parameter was measured from an automatic weather station located at the center of greenhouse presented in Table 1.

2.2. Experimental design

To find the effect of water and fertilizer application on tomato growth index, yield and quality, the experiment was conducted based on Randomized Block Design with two factors: irrigation and fertilizer (Urea & Potash). Irrigation was initiated at four different levels of water field capacity (%FC): W₁ (65%), W₂ (75%), W₃ (85%) and W₄ (100%) and Urea (N) & Potash (K) applied by mixing with irrigation water which also designed at four different levels: N₁-245 & K₁-490, N₂-350 & K₂-700, N₃-455 & K₃-910 and N₄-80 & K₄-100 kg ha⁻¹. The control (CK) was designed from local farmer practiced water and fertilizer application (100% FC with @80 kg ha⁻¹ urea and @100 kg ha⁻¹ potash). Therefore, total ten treatments including CK were designed as follows: T₁-W₁N₁K₁, T₂-W₁N₂K₂, T₃-W₁N₃K₃, T₄-W₂N₁K₂, T₅-W₂N₂K₃, T₆-W₂N₃K₁, T₇-W₃N₁K₃, T₈-W₃N₂K₁, T₉-W₃N₃K₂ and CK-W₄N₄K₄. The treatments were designed with five replications each of 7 m long and 1.5 m wide plots in total areas was 52.5 m². The distance between two adjacent plots was kept at 0.3 m. All replications were covered by 0.004 mm thin black plastic mulch to reduce evaporation losses. The details of the experimental layout are depicted in Figure 1.

Table 1. Monthly average micro-climatic status into greenhouse during cropping season

Month	Temperature (°C)	Relative humidity, RH (%)	Sunshine duration (hour)
February	17.89	76.27	8.4
March	20.43	65.37	9.3
April	18.63	74.27	11.8
May	19.60	65.84	14.0
June	23.65	69.81	14.6
July	26.15	76.53	14.8

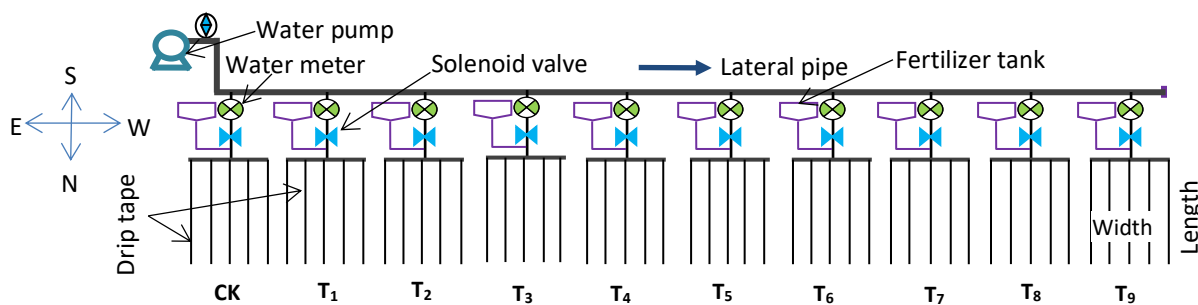

Figure 1. Experimental layout

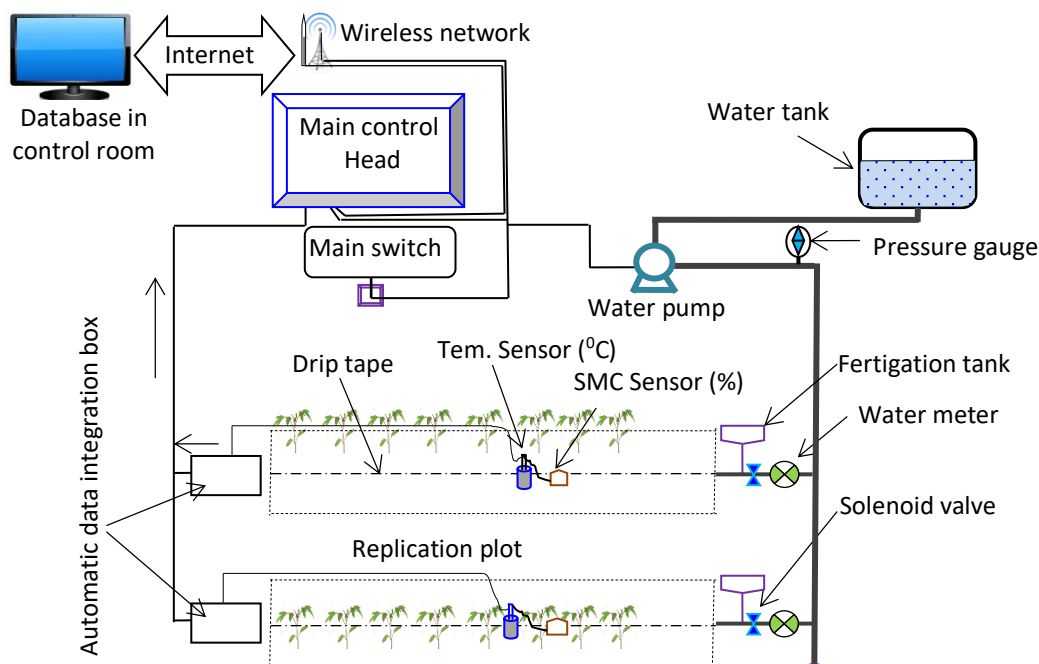

Figure 2. Sketch of intelligent drip irrigation system in the experiment

2.3. Description of experimental intelligent drip system

The irrigation method used an intelligent drip system developed by ‘Witu High-tech Corporation’ China based on wireless network sensors from the root zone to automated water pump via control station. The components of this system are main control box, automatic data integration box, computer with control software, wireless transmission equipment, fertigation tank, water meter, solenoid valve and electromagnetic sensors as shown in Figure 2. The data integration boxes monitored and collect soil moisture content and temperature by attached sensors which transfer through a wireless network transmission system to control box. The system automatically analyzes data, and calculates water requirements and then a command is sent to the main control box which activates the sensor to operate the pump. For achieving different irrigation level in different treatments, drip tape was connected with a separate pvc sub-line with water meter and solenoid valve to the main pvc line. After achieving irrigation up to the target was set, solenoid valve automatically closed which corresponds to the water pump. The main lateral pvc pipe was used 32 mm outer and 25 mm inner diameter for water delivery from the water tank to dripping tape. The dripping tape 0.2 mm thick polyethylene type with 16 mm outer diameter was laid on the center of each plot. The dripping tape was made water drop spacing at

0.3 m and dripping flow capacity was 1.38 l hr⁻¹ with 0.1 MPa bearing capacity.

2.4. Agronomic management

The tomato is a local variety (Chinese name: ‘Ao-Te-You’) was planted using two rows in each plot as shown in Figure 3. Each plot stage width and stage height was 1.2 m and 0.15 m respectively. The row spacing of tomato plant was 0.6 m and plant to plant distance maintained at 0.4 m. The adjacent distance between an individual plant and emitting point of water-dripping tape was set as 0.3 m. Each row contains 17 plants, which makes a total number of 34 transplanted plants per plot. The soil was properly tilled and beds were raised to required height before transplanting seedlings. During

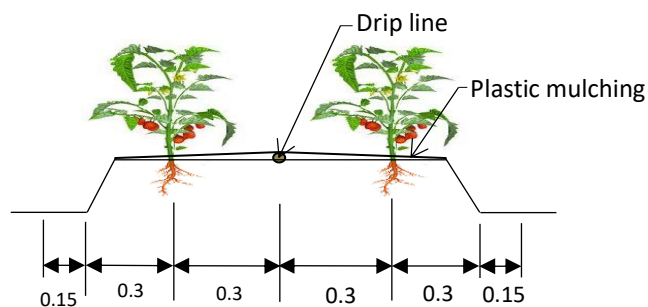

Figure 3. Schematic illustration of plot design (unit in m)

secondary tillage Acetochlor powder (Chloroacetamide herbicide) @ 1.5 kg ha⁻¹ were applied uniformly to the soil. At the same time two types of base fertilizer were also applied equally in all treatments: (i) Organic manure-@300 kg ha⁻¹ and (ii) Potassium dihydrogen phosphate (KH₂PO₄)-@316 kg ha⁻¹ with 52% P content. From plant development stage, fertilizer was applied six times with an equal interval until the last harvesting period by mixing with irrigation water according to the experimental design. To ensure maximum plant survival rate at initial stage 0.55 m³ (10.5 mm) of water per plot was applied equally for the first month. The tomato was trained for vertical growing only the main branch using rope. For controlling disease fungicides (Trifluoromethyl-3) solution (1 ml l⁻¹) was sprayed on the surface of the tomato plants during 3-5 leaves period.

2.5. Data measurement

2.5.1. Irrigation measurement

Irrigation was scheduled by monitoring soil moisture content (SMC) through the cropping period. The SMC was measured between 10-40 cm soil depths using a moisture content probe. The probe contains four ring sensors fixed at 10 cm interval along the inner hub. Concurrently, Gravimetric method was also used to determine SMC at 20 cm soil depth. Both SMC measurements were calibrated and seen to have a similar trend between 20-30 cm soil layer depths, thus irrigation was scheduled based on the SMC at 20 cm soil depth. Similarly, Alaoui et al. (2014) reported that tomato roots were develop better at 10-40 cm soil layer depth. However, the irrigation was estimated by volumetric water content using Equation 1 for directed irrigation as follows (Mamun Hossain et al., 2017) :

$$m = 0.1(\beta_f - \beta_0)H\rho\gamma \quad [1]$$

Where, m , β_f , β_0 , H , γ and ρ stand for water requirement (mm), Initial SMC (%FC), measured SMC (%FC), soil layer depth (m), soil bulk density (t m⁻³) and wetting perimeter (%) respectively. For vegetable crops in the drip irrigation system, the value of ρ was used as 70%. The water requirements (mm) were converted into m³ for easily read by water meter.

2.5.2. Estimation of actual evapotranspiration (ET_a)

The seasonal actual evapotranspiration (ET_a) was calculated using Equation 2 by monitoring of soil moisture balance technique as follows (Chen et al., 2014; Zheng et al., 2013):

$$ET_a = I + P_e \pm \Delta S - R - D \quad [2]$$

Where, ET_a is actual evapotranspiration (mm); I , P_e , ΔS , R and D stand for the amount of water application in tomato cropping period (mm), effective rainfall (mm), soil water storage change (mm) between two consecutive moisture measurements at the same root zone depth, surface runoff (mm) and deep percolation (mm) respectively. In greenhouse there was no rain, therefore $P_e = 0$. We also considered no runoff and percolation occurred due to water applied in intelligent-controlled rate. Also consider no contribution from groundwater, because water table is more than 20 m depth

in this research area. Therefore, actual ET_a was calculated using Equation 3 simply as follows:

$$ET_a = I \pm \Delta S \quad [3]$$

Where, I and ΔS are the amount of water application measured by water meter and changes of soil water storage respectively.

2.5.2. Growth index measurement

The tomato growth index on the basis of leaf area index (LAI) were measured by selecting 3 cluster points from each plot, in which total 15 measurements from in each treatment. The measurements were taken at 10 days interval using Accu PAR Ceptometer, called Canopy Analyzer (Zhai et al., 2015) LP-80, Decagon Devices, Germany. The measurement started from 10 days after transplanting and lasted up to the next 40 days. The data were taken from digital screen by inserting the Ceptometer's probe under plants canopy.

2.5.3. Yield and fruits quality measurement

The tomato fruit harvesting started from 50 days after transplanting. Fruits were harvested from 5 randomly selected 1 (one) m² area in each treatment at 3-5 days interval. An electronic balance was used to weigh the harvested fruits and yield (kg m⁻²) was determined using Equation 4 as follows (Hamza & Almasraf, 2016; Mamun Hossain et al., 2018):

$$\text{Yield} = \frac{\text{Total weight of harvested tomato (Kg)}}{\text{Total area of harvested tomato (m}^2\text{)}} \quad [4]$$

Finally, the cumulative yield values were converted into t ha⁻¹. Tomato fruit's weight (FW) and diameter (FD), which represent the fruit's physical quality was determined after harvesting by randomly selecting three fruits from each replication. Therefore, 15 fruits per treatment were collected for physical quality measurement. The FW (g) and FD (mm) were determined using electronic balance and Vernier caliper respectively.

2.5.4. Determination of water use efficiency (WUE)

The water use efficiency expressed in kg m⁻³ was determined in terms of fruit yield and volumetric water application using Equation 5 as used by many researchers (Buttaro et al., 2015; Chen et al., 2013; Mamun Hossain et al., 2018) as follows:

$$WUE = \frac{Y}{m} \quad [5]$$

Where, WUE is water use efficiency (kg m⁻³), Y is fruits yield (kg ha⁻¹) and m is crop water consumption (m³ ha⁻¹).

2.6. Statistical analyses

To assess the significant effects of different treatments on tomato growth index, yield and fruit quality, data were statistically analyzed by general linear model. Differences between means were calculated for the significance test by analysis of the least significant differences (LSD) test at $p = 0.05$ level. All statistical processes were administered by IBM-SPSS statistics 19.0 version software. A regression analysis

was carried out to establish a linear model for determine the influence of input variables to yield. Water application, nitrogen and potash were considered as explanatory variables. The purpose of the linear model ($Y = \alpha + \beta_1 X_1 + \beta_2 X_2 + \beta_3 X_3$) is to estimate the predicted tomato yield in relation with the input variables. Where, $Y, \alpha, (\beta_1, \beta_2, \beta_3)$ and (X_1, X_2, X_3) stand for observed yield, constant value, coefficient of variance and independent variables respectively. The model was validated with values within the variables range based on root mean square error (RMSE) and coefficient of determination (r^2).

3. RESULTS

3.1. Soil temperature, moisture content and evapotranspiration (ET_a) status

The daily average soil temperature in the tomato growing period for 10 and 20 cm soil depth was established a similar trend as shown in Figure 4. The soil temperature fluctuation range was revealed between 18.19 °C to 26.33 °C with an average of 20.55 °C in entire cropping period. The average temperature is placed within the recommended range of conductive environment for optimum root growth (Shamshiri et al., 2018). The results of soil moisture content (SMC) at 20 cm depth for all treatments were seen to increase with irrigation and decreased after water consumption. The actual seasonal evapotranspiration (ET_a) of tomato for all treatments are given in Table 2. The seasonal ET_a ranged from 66.44 to 200.04 mm corresponding to the different irrigation level increased linearly with the amount of water application as shown in Figure 5. This linearity shown, because water applied in controlled rate with avoiding runoff, percolation and evaporation losses. Which means most of the applied water was consumed as evapotranspiration. The seasonal ET_a was calculated as maximum and minimum for water applied at 100% (W_4) and 65% (W_1) of water field capacity respectively.

The ET_a shows minor variation at the same level of irrigation which could be for plant water uptake variation and soil-water situation of respective treatment. Therefore, the seasonal ET_a was increased mainly due to increases of water application.

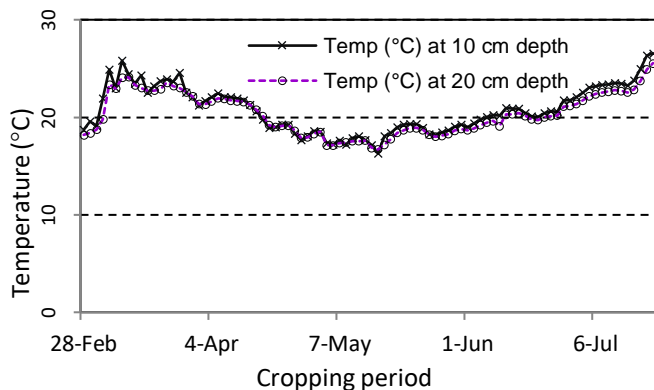

Figure 4. Daily average temperatures (°C) at different depth of greenhouse soil during tomato period

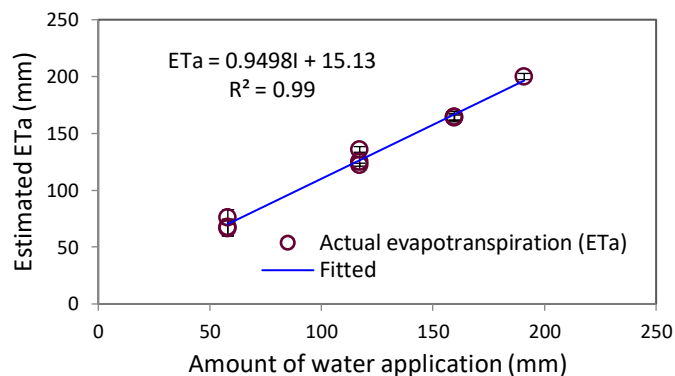

Figure 5. Relationship between actual evapotranspiration (ET_a) and amount water application (error bar denotes standard deviation).

Table 2. Effect of water application on actual evapotranspiration (ET_a) of tomato

Treatments	I (mm) †	ΔS (mm) †	ET_a (mm) †
T ₁	58.10	8.34±6.78 ^{a1}	66.44±6.78 ^a
T ₂	58.21	18.21±6.44 ^b	76.42±6.44 ^b
T ₃	58.11	9.44±7.10 ^a	67.55±7.10 ^a
T ₄	117.14	18.78±2.49 ^b	135.92±2.49 ^d
T ₅	117.12	5.37±1.31 ^a	122.49±1.31 ^c
T ₆	117.22	7.81±6.89 ^a	125.03±6.89 ^c
T ₇	159.62	4.77±2.93 ^a	164.39±2.93 ^e
T ₈	159.65	4.33±2.20 ^a	163.98±2.20 ^e
T ₉	159.62	5.06±4.51 ^a	164.68±4.51 ^e
CK	190.86	9.18±2.70 ^a	200.04±2.70 ^f
CV (%)		57.82	36.03
F-ratio	-	5.95	459.11
Mean Square	-	23.42	23.43
p test	-	**	***

Remarks: Mean values ± standard deviation. †, amount of seasonal water application; ΔS , changes of soil water storage; ET_a , actual seasonal evapotranspiration; Small letter within columns indicate mean values are significantly different according to LSD ($p = 0.05$) test. ‘***’ means $p < 0.001$, ‘**’ means $0.001 < p < 0.01$.

3.2. Effect of treatments on growth index (LAI)

The effect of treatments on tomato leaf area index (LAI) is given in Table 3. The highest value of LAI was obtained at 5.21 with treatment T₇ at 40 days after transplanting, which was found 11% greater compared to the CK (4.62). The statistical analysis showed that LAI had significantly influenced by all treatments at 30 ($p < 0.001$) and 40 ($p < 0.05$) days after transplanting. At 30 days after transplanting treatment T₃, T₇ and T₈ showed significant differences when compared to other treatments.

3.3. Effect of treatments on tomato yield

The effect of treatments on tomato yield is given in Table 4. The highest tomato yield of 103.16 t ha⁻¹ was obtained with treatment T₈ while the CK yield (100.92 t ha⁻¹) was found as medium of all the treatments. The highest yield was found 8% and 2% greater compared to the lowest (94.65 t ha⁻¹) with T₂ and CK yield respectively. Also, 15% more water was saved with the treatment T₈ compared to CK. The lowest tomato yield was obtained from treatment T₂ which could be due to a large difference in irrigation (35% less of FC), thus water deficit.

Table 3. Effects of treatments on tomato LAI

Treatment	Cropping period/(+D)			
	10	20	30	40
T ₁	1.79±0.4 ^{a1}	2.60±0.3 ^a	4.29±0.3 ^c	5.15±0.2 ^a
T ₂	1.97±0.4 ^a	2.18±0.2 ^a	3.14±0.1 ^{ab}	4.98±0.2 ^a
T ₃	2.13±0.5 ^a	2.04±0.7 ^a	2.50±0.3 ^a	5.00±0.5 ^a
T ₄	1.88±0.3 ^a	2.25±0.2 ^a	3.13±0.6 ^{ab}	4.78±0.1 ^a
T ₅	1.64±0.3 ^a	2.34±0.3 ^a	3.06±0.6 ^{ab}	4.41±0.3 ^a
T ₆	1.75±0.1 ^a	1.88±0.3 ^a	2.59±0.3 ^{ab}	4.07±0.8 ^a
T ₇	2.31±0.7 ^a	2.77±0.4 ^a	3.51±0.5 ^{abc}	5.21±0.5 ^a
T ₈	1.72±0.7 ^a	2.55±0.3 ^a	3.41±0.2 ^{abc}	4.10±0.8 ^a
T ₉	1.89±0.4 ^a	2.86±0.6 ^a	3.62±0.4 ^{bc}	4.50±0.1 ^a
CK	2.10±0.1 ^a	2.39±0.3 ^a	3.14±0.3 ^{ab}	4.62±0.3 ^a
Statistical test				
CV (%)	10.96	13.13	15.89	8.78
$p_{(I*N*K)}$	0.714 ^{ns}	0.092 ^{ns}	0.001 ^{**}	0.042 [*]
Mean Square	0.13	0.30	0.79	0.51
F-ratio	0.685	2.017	5.331	2.507

Remarks: Mean LAI ($m^2 m^{-2}$) ± Standard deviation; +D = Days after transplanting. Same letter within columns indicate mean values are not significantly different according to LSD ($p = 0.05$) test; *, **, level of significance at $p < 0.05$, $p < 0.01$ respectively; ns, non-significance.

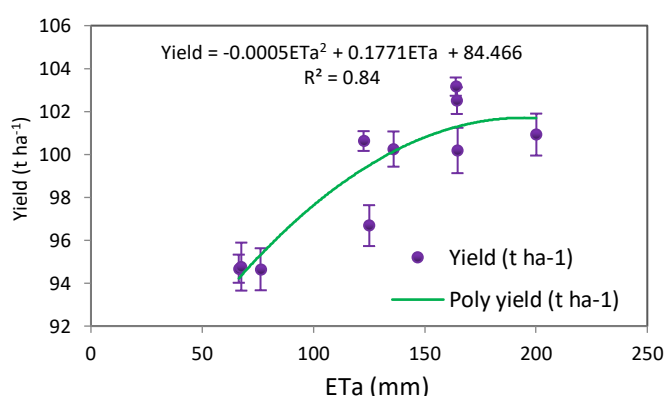

Figure 6. Relationship between seasonal evapotranspiration (ET_a) with tomato yield; Error bar represents the standard deviation.

A polynomial relationship showed a fitted functional relation ($Y = -0.0005ET_a^2 + 0.1771ET_a + 84.466$) of actual seasonal ET_a (mm) and tomato yield ($t ha^{-1}$) with $r^2 = 0.84$ as shown in Figure 6. This relation indicated that tomato yield increased with the increase of irrigation and after a certain level of irrigation the yield was declined. These could be indicated that a certain level of deficit irrigation could produce improve yield. However, the interaction effect of irrigation and fertilizer (NK) on tomato yield given in Figure 7. (a, b), which indicated the improve yield could be produced by an appropriate urea-potash (N_2K_1) combination. The statistical analysis shows a significant influence on tomato yield by all treatments (Table 4). Similarly, LSD test shows individual water, N and K applications significantly ($p < 0.001$) influenced on tomato yield. It also indicated that the yield of T₁, T₂ and T₃ is found significantly different compared to others treatments.

3.4. Effect of water use efficiency (WUE)

The effect of treatments on WUE is given in Table 4. The highest WUE of $163.13 kg m^{-3}$ was obtained with treatment

T₃, whereas the lowest $52.88 kg m^{-3}$ was recorded with CK. The WUE of the W₁ group was found exceptionally high compared to CK and W₃ group of treatments. This could be due to deficit (35% and 25%) irrigation, however, the yield does not decrease accordingly. The statistical analysis showed that WUE is significantly different from all treatments except T₁ and T₂. Also, the LSD test shows independently water and urea (N) significantly ($p < 0.001$) influenced on WUE more precisely than potash (K) application ($p < 0.01$). Therefore, the WUE increases mainly with increasing deficit water application, however, this might not be at the expense of yield.

3.5. Effect on tomato quality

The tomato fruit's physical quality in terms of fruit weight (FW) and diameter (FD) is presented in Table 4. The highest FW $288.77 g$ was obtained with treatment T₂, while the lowest of $147.97 g$ was recorded with CK. The highest FW is found 49% greater compared to the CK. The statistical analysis shows the FW for all treatments was perceived to have significantly ($p < 0.01$) influenced by fertilizer (N, K) application. This could be for fertilizer has additional effects on fruits formation. The LSD test indicated that treatment T₂ was found significantly different compared to others. The biggest size (diameter) of tomato fruit (FD) was obtained at $85.33 mm$ with treatment T₂ (Table 4), while the CK has the smallest fruit size of $67.41 mm$. The FD of CK was found 21% less than the biggest size. The relationships between actual ET_a versus FW & FD and fertilizer (N, K) versus FW & FD also showed distinct influences as depicted in Figure 8 (a,b,c). This indicated that deficit irrigation can produce better quality tomato, as the highest FW and FD with treatment T₂ was obtained by 35% deficit irrigation (Table 4). This also specified that tomato fruits size was influenced more by appropriate fertilizer combinations.

Table 4. Effect of treatments on fruits physical quality, yield and WUE of tomato

Treatments	FW (g) †	FD (mm) †	Yield (t ha ⁻¹)	WUE (kg m ⁻³) †
T ₁	202.17±63.0 ^{ab1}	73.87±9.7 ^{ab}	94.67±0.66 ^a	162.97±1.13 ^h
T ₂	288.77±37.3 ^b	85.33±4.2 ^b	94.65±0.98 ^a	162.92±1.69 ^h
T ₃	229.90±38.4 ^{ab}	77.72±6.5 ^{ab}	94.77±1.12 ^a	163.13±1.93 ⁱ
T ₄	240.20±26.5 ^{ab}	82.60±2.6 ^b	100.25±0.82 ^c	85.58±0.70 ^f
T ₅	246.67±31.5 ^{ab}	82.44±3.7 ^b	100.62±0.46 ^d	85.90±0.39 ^g
T ₆	251.50±13.8 ^{ab}	81.38±2.2 ^{ab}	96.68±0.95 ^b	82.53±0.82 ^e
T ₇	249.40±79.4 ^{ab}	82.15±7.7 ^{ab}	102.50±0.62 ^f	64.21±0.39 ^c
T ₈	225.67±14.6 ^{ab}	78.98±2.3 ^{ab}	103.16±0.43 ^g	64.63±0.27 ^d
T ₉	226.67±24.7 ^{ab}	78.98±2.3 ^{ab}	100.18±1.06 ^c	62.76±0.66 ^b
CK	147.97±13.3 ^a	67.41±3.9 ^a	100.92±0.98 ^e	52.88±0.51 ^a
Statistical test				
CV (%)	15.95	6.57	3.36	46.21
ρ Irrigation (I)	ns	Ns	***	***
ρ Nitrogen (N)	**	**	***	***
ρ Potash (K)	**	***	***	**
ρ I*N*K interaction	**	***	***	***
Mean square	4412.63	91.63	647.84	1009.09
F-ratio	3.42	5.16	924.32	1035.18

Remarks: Mean values ± standard deviation; †FW, Fruit weight; FD, Fruit diameter; WUE, water use efficiency. Small letter within columns indicate mean values are significantly different according to LSD ($p = 0.05$) test; '***' means $p < 0.001$, '**' means $0.001 < p < 0.01$, 'ns' means $p > 0.05$.

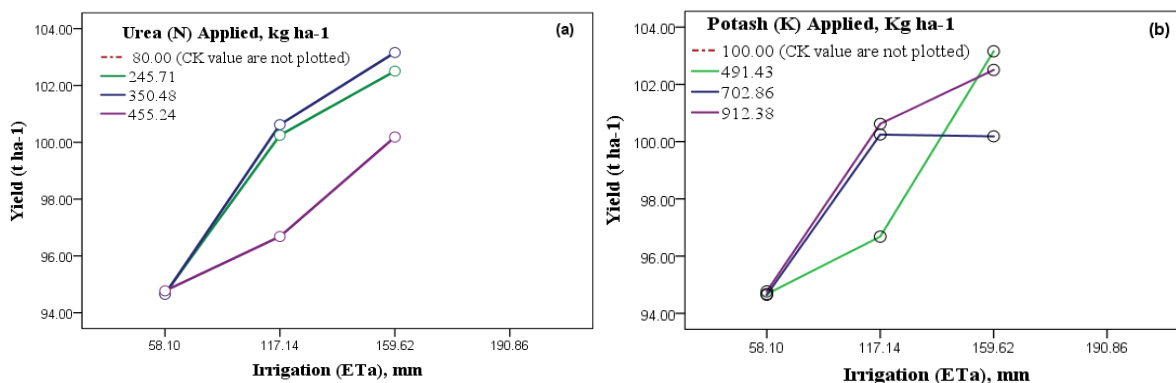
**Figure 7.** Irrigation (ET_a) and fertilizer (a) Urea, (b) Potash interaction effect on tomato yield

The statistical analysis indicated that FD does not significantly influence by irrigation. However, fertilizer (N, K) application significantly ($p < 0.01$) influenced FD. The LSD test showed the treatments T₂ and T₄ were found significantly different compared to others. Although FW and FD for T₂ were given the highest value, however, the total yield was not the highest, which could be for deficit irrigation.

3.6. Performance of the regression Model

The regression model (Equation 6) was developed to study the response of water, nitrogen and potash application on tomato yield.

$$Y = 89.08884 + 0.066303 * X_1 - 0.0045213 * X_2 + 0.0050969 * X_3 \dots \dots [6]$$

Where, Y, X₁, X₂ and X₃ are yield (t ha⁻¹), amount of water (mm), urea and potash (kg ha⁻¹) application, respectively. In this study, the model estimated the predicting yield values

were analyzed as statistically significant ($p < 0.01$), in which the coefficient of determination (r^2) and root mean square error (RMSE) is 0.82 and 1.43 respectively. These values indicate the variability of data around the regression line has a better degree of relationship among yield, water and fertilizer. The performance of this model in predicting tomato yield was evaluated by validated predicted yield data with observed data. We established a linear relation ($Y_p = 0.824Y_o + 17.424$) for best fitting the model, in which Y_p and Y_o is predicted and observed tomato yield (t ha⁻¹) respectively as shown in Figure 9. This relationship indicated a superior model fit ($r^2 = 0.82$) with predicted and observed yield, which could be a close agreement among both values with 82% accuracy.

4. DISCUSSION

The effect of water and fertilizer application in greenhouse for tomato growth index, yield and fruit quality are shown in

Table 3 and Table 4. The highest improved tomato yield showed in treatment $T_8-W_3N_2K_1$ (Table 4) by the influence of diminishing water field capacity (85% FC) and fertilizer (N_2K_1) combination, while the control (CK) including high water (100% FC) and local practiced low fertilizer (NK) combination resulted in the almost average yield of the total treatments. Results showed the highest LAI (5.21) in the treatment combination of $T_7-W_3N_1K_3$ which produced an improved tomato yield of 102.50 t ha^{-1} . Whereas the highest improved yield (103.16 t ha^{-1}) of the experiment was influenced by the treatment combination of $T_8-W_3N_2K_1$ that revealing a relatively less LAI (4.10) than the highest. This indicated that the tomato growth and improve yield were produced by the potential influence of a handsome amount (15% deficit) of water-fertilizer combination. It could be for the enhancement of plant-nutrient uptake by accurate intelligent drip fertigation as it proved and noticed by Ankush et al. (2017) and Wang and Xing (2017). These circumstances are also geared by used plastic mulching of all treatments. Comparable results also noticed by Hou et al. (2017) and Mamun Hossain et al. (2017) that, most LAI was recorded with less variation between different water field capacity (%FC) with NPK fertilization by non-destructive method thus the yield accordingly. The result difference LAI in between the treatment T_7 and T_8 could be due to the proper amount of water-fertilizer combined application. Nonetheless, Pires et al. (2011) reported the highest LAI which produced the highest yield accorded with the present study. The results also indicated that the urea-potash combination influenced the LAI and correspondingly influenced the yield, though a healthy LAI with the highest improved tomato yield was produced by 15 to 25% deficit fertigation. It also indicated that a proper combination of drip fertigation could be a good compromise for solar greenhouse-grown tomatoes (Wang & Xing, 2017).

Numerous studies reported greenhouse tomato yields in different application and environment. Some of the highest yield were 112.81 , 119.4 , 110.66 and 97.1 t ha^{-1} analogous with this present study as noticed by Sun et al. (2013), Chen et al. (2014), Al-Harbi et al. (2015), and Xiukang and Yingying (2016) respectively. Proper fertilizer combination also helped to produce improved tomato yield (Wang & Xing, 2017). Because in W_1 group treatments the yield shows little variation within the group, this could be the effect of equivalent range of urea and potash (NK) combination. In treatments combination T_4 , T_5 and T_6 with the same irrigation level (W_2) the T_6 with inappropriate urea and potash (N_3K_1) combination give comparatively low yield than T_4 and T_5 . Likewise, Khan et al. (2017) reported inappropriate fertilizer combinations resulted in decreased tomato yield. Sun et al. (2013) also noticed tomato yield 112.92 t ha^{-1} for 296 mm drip fertigation, which also consisted with this study. In general it is indicated that water application had influenced on tomato yield and the degree of influence enhanced by appropriate fertilizer combination. It may be for higher plants nutrients uptakes, which boosted by intelligent control drip system into active root zone without leaching, runoff and percolation losses (Zhang et al., 2017). Nevertheless, the interactive effects of an appropriate water-fertilizer combination increase the plant leaf's photosynthetic pigment contents, leaf soluble sugar, superoxide dismutase and decrease the

gas exchange that affects on chlorophyll fluorescence which enhances the leaf resistance and metabolism. The leaf resistance and metabolism positively influence on net photosynthesis rate towards improve yield (Guo et al., 2021; Zhu et al., 2012).

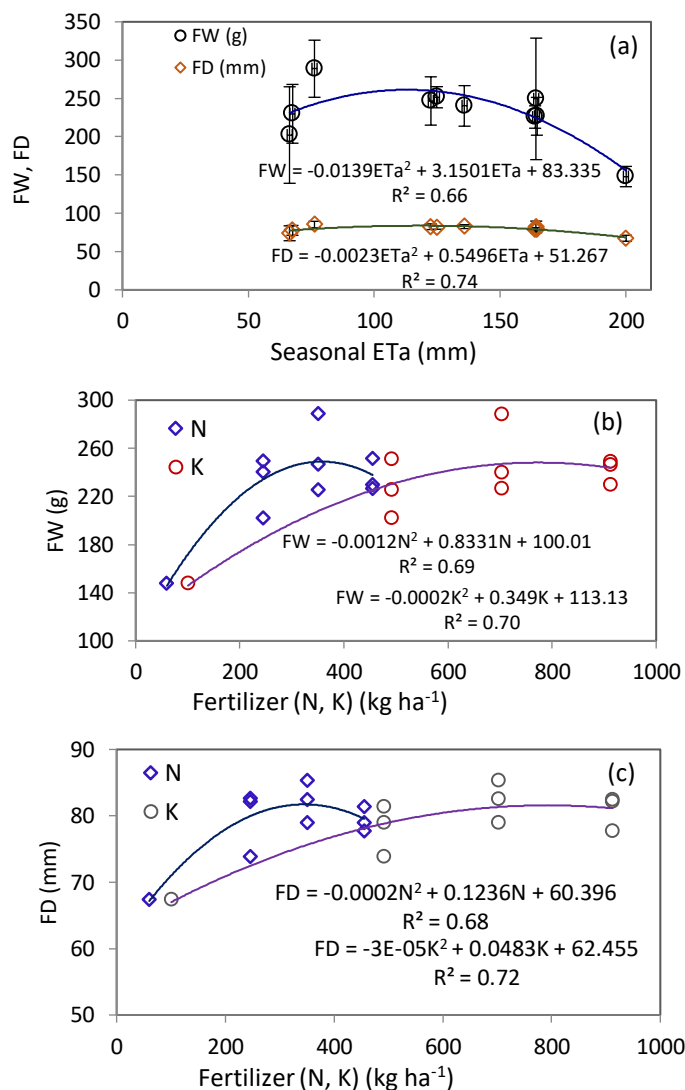

Figure 8. Relationship between (a) water (ET_a)-fruit weight and diameter, (b) fertilizer-FW and (c) fertilizer-FD.

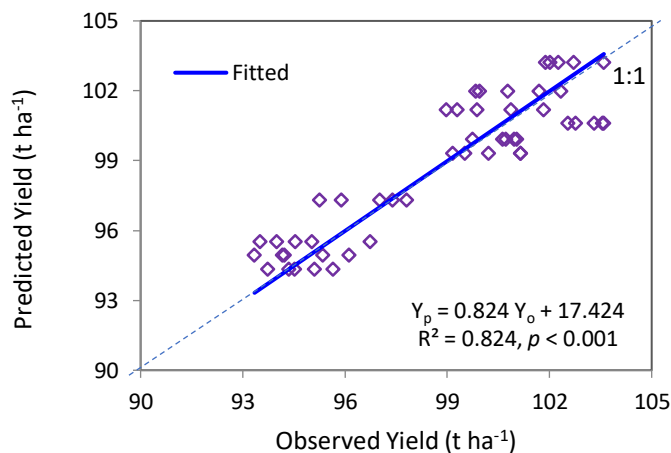

Figure 9. Comparison of predicted and observed tomato yield depicted the model validation

The WUE also increased in the reduction of seasonal evapotranspiration (ET_d), which also confirmed by many researcher. Chen et al. (2013), Buttaro et al. (2015), and Biswas et al. (2015) noticed comparable results of WUE for greenhouse tomato production. The treatments with deficit (35% and 25%) irrigation increase the WUE because the yield does not decrease as deficit. This could be due to appropriate combination of fertigation in greenhouse condition and using plastic mulching constantly hold the water in field capacity, which also escalates the active root zone. Moreover, due to plastic mulch soil retain the moisture content at field capacity possibly long time, which aided to develop of beneficial plant-associated microbes is a source of energy that influence the plant root metabolism. These metabolic system has the potentiality to increase plant growth, fertilizer use efficiency, stress tolerance and disease resistance capacity thus improved the yield in appropriate water-fertilizer combination (Mamun Hossain et al., 2021; Trivedi et al., 2017). Therefore it indicated that, appropriate water and fertilizer combination given improve yield and it could be recommended for greenhouse tomato production.

In this study, the LAI values of treatment combination were recorded higher than in various antecedent research, however, the yield was not so high accordingly. This could be due to the influence of nutrients uptake rate, long-duration of solar radiation and plant species. Moreover, the higher LAI recorded could be because of intelligent-control drip irrigation with fertilization which accorded more benefit to plant growth. Even in that case, the treatment combination T₂ showed near to highest LAI (4.98) which produced the highest physical quality of tomato, yet the yield was not the highest. The utmost FW noticed by Chen et al. (2013), Zheng et al. (2013), and Al-Harbi et al. (2015) were consisted with the present study. However, comparable FD was noticed by Zheng et al. (2013) and Alaoui et al. (2015) which also showed similarities to the present result. The results also showed better quality tomato fruits in most treatments except the treatment of poor fertilizer combination. Thus, it indicated that tomato fruits' quality influenced by a range of fertilizer combination that is recommended for application.

The regression model showed a predicting yield in response of water and fertilizer (NK) application. Several researchers reported different water-yield models based on evapotranspiration which is comparable with this study (Chen et al., 2014; Kuşçu et al., 2014; Patanè et al., 2011; Zheng et al., 2013). However, Sun et al. (2013) noticed a best fitted ($r^2 = 0.99$) validation result of EU-Rotate N model, which also justify the present model. As this model is a pragmatic model, hence the application maybe delimited to the location and same environmental circumstances. Therefore, the present model could be used as an appropriate predictor to find the improved tomato yield.

5. CONCLUSIONS

The different water field capacity and urea-potash combinations in greenhouse produced improve tomato yield with good fruit quality. The leaf area index (LAI) influenced the improve yield although minimal variation of yield was found in between treatments of the same irrigation level. However,

the highest tomato LAI did not influence the highest yield. Apparently, the treatment combinations produced growth index, improve tomato yield and fruit physical quality, merely the proper fertilizer (NK) combination was explicitly influenced on fruit quality. Moreover, the influence of potash over nitrogen application on fruit physical quality was distinguished. Although the highest plant growth index (LAI) and fruit size (weight & diameter) did not affect on highest yield. Therefore, the yield was satisfied using deficit irrigation with a moderate level of fertigation compared with the CK. However, the effect of water on yield is more notable. In conclusion, future study is important to estimate the optimum water and fertilizer combination to lead the improved tomato yield using an intelligent drip system.

Declaration of Competing Interest

The authors declare no competing financial or personal interests that may appear and influence the work reported in this paper.

References

- Al-Harbi, A. R., Al-Omran, A. M., Alenazi, M. M., & Wahb-Allah, M. A. (2015). Salinity and Deficit Irrigation Influence Tomato Growth, Yield and Water Use Efficiency at Different Developmental Stages. *International Journal of Agriculture & Biology*, 17(2).
- Alaoui, S., Salghi, R., Abouatallah, A., & Ayoub, M. (2015). Impact of drip irrigation scheduling on fruit quality parameters and water use efficiency on tomato plant (*Lycopersicon esculentum* Mill.) under unheated greenhouse. *Journal of Materials and Environmental Science*, 6(2), 315-321. http://jmaterenvirosci.com/Document/vol6/vol6_N_2/38-JMES-1096b-2014-Alaoui.pdf
- Alaoui, S., Salghi, R., Abouatallah, A., Jaouhari, N., & Hammouti, B. (2014). Impact of drip irrigation scheduling on vegetative parameters in tomato (*Lycopersicon esculentum* Mill.) under unheated greenhouse. *International Journal of Engineering Research and Applications*, 4(1), 71-76. http://www.ijera.com/papers/Vol4_issue1/Version%203/L41037176.pdf
- Ankush, A., Singh, V., & Sharma, S. (2017). Response of tomato (*Solanum lycopersicum* L.) to fertigation by irrigation scheduling in drip irrigation system. *Journal of Applied and Natural Science*, 9(2), 1170-1175. <https://doi.org/10.31018/jans.v9i2.1342>
- Appasaheb, S. A., Reddy, K. N., & Papachary, B. (2015). Auto Irrigation System for Monitoring and Controlling of Adverse Conditions in Agriculture through GPRS. *International Journal of Engineering Research and Applications (IJERA) NATIONAL CONFERENCE on Developments, Advances & Trends in Engineering Sciences (NCDATES- 09th & 10th January 2015)*, 22-26. http://www.ijera.com/special_issue/NCDATES/ECE/PART-3/ECE%20151-2226.pdf
- Biswas, S., Akanda, A., Rahman, M., & Hossain, M. (2015). Effect of drip irrigation and mulching on yield, water-use efficiency and economics of tomato. *Plant, Soil and*

- Environment*, 61(3), 97-102.
<https://doi.org/10.17221/804/2014-PSE>
- Buttaro, D., Santamaria, P., Signore, A., Cantore, V., Boari, F., Montesano, F. F., & Parente, A. (2015). Irrigation Management of Greenhouse Tomato and Cucumber Using Tensiometer: Effects on Yield, Quality and Water Use. *Agriculture and Agricultural Science Procedia*, 4, 440-444.
<https://doi.org/10.1016/j.aaspro.2015.03.050>
- Chen, J., Kang, S., Du, T., Guo, P., Qiu, R., Chen, R., & Gu, F. (2014). Modeling relations of tomato yield and fruit quality with water deficit at different growth stages under greenhouse condition. *Agricultural Water Management*, 146, 131-148.
<https://doi.org/10.1016/j.agwat.2014.07.026>
- Chen, J., Kang, S., Du, T., Qiu, R., Guo, P., & Chen, R. (2013). Quantitative response of greenhouse tomato yield and quality to water deficit at different growth stages. *Agricultural Water Management*, 129, 152-162.
<https://doi.org/10.1016/j.agwat.2013.07.011>
- FAO. (2017). *The future of food and agriculture—Trends and challenges* (Vol. 296). Food and Agriculture Organization of the United Nations. Rome.
- Guo, X., Li, S., Wang, D., Huang, Z., Sarwar, N., Mubeen, K., . . . Hussain, M. (2021). Effects of water and fertilizer coupling on the physiological characteristics and growth of rabbiteye blueberry. *PLoS One*, 16(7), e0254013.
<https://doi.org/10.1371/journal.pone.0254013>
- Hamza, A. A., & Almasraf, S. (2016). Evaluation of the yield and water use efficiency of the cucumber inside greenhouses. *Journal of Babylon University/Engineering Sciences*, 24(1), 95-106.
<https://www.iasj.net/iasj/download/c7bfd2134e82b57>
- Hou, M., Jin, Q., Lu, X., Li, J., Zhong, H., & Gao, Y. (2017). Growth, Water Use, and Nitrate-15N Uptake of Greenhouse Tomato as Influenced by Different Irrigation Patterns, 15N Labeled Depths, and Transplant Times [Original Research]. *Frontiers in Plant Science*, 8. <https://doi.org/10.3389/fpls.2017.00666>
- Khan, A. A., Bibi, H., Ali, Z., Sharif, M., Shah, S. A., Ibadullah, H., . . . Ali, S. (2017). Effect of compost and inorganic fertilizers on yield and quality of tomato. *Academia Journal of Agricultural Research*, 5(10), 287-293.
<https://academiapublishing.org/journals/ajar/abstract/2017/Oct/Khan%20et%20al.htm>
- Kishore, Y. N., & Chaitanya, J. K. (2014). Automatic monitoring and controlling of greenhouse environment using wireless sensor network. *International Journal of Science, Engineering and Technology Research*, 3(9), 2395–2399.
- Kuşçu, H., Turhan, A., & Demir, A. O. (2014). The response of processing tomato to deficit irrigation at various phenological stages in a sub-humid environment. *Agricultural Water Management*, 133, 92-103.
<https://doi.org/10.1016/j.agwat.2013.11.008>
- Luvai, A. K., Gitau, A. N., Njoroge, B. N. K., & Obiero, J. P. O. (2014). Effects of Water Application Levels on Growth Characteristics and Soil Water Balance of Tomatoes in Greenhouse. *International Journal of Engineering Innovations and Research*, 3(3), 271-278.
http://ijeir.org/administrator/components/com_jreseaarch/files/publications/IJEIR_932_Final.pdf
- Mamun Hossain, S. A. A., Kayum, M. A., Wang, L., & Shahin, M. (2021). Effect of drip irrigation scheduling and mulching practice on pointed gourd (*Trichosanthes dioica* Roxb.) pot-cultivation in Patuakhali Bangladesh. 17(4), *International Journal of Agricultural Technology*.
[http://ijat-aatsea.com/pdf/v17_n4_2021_July/14_IJAT_17\(4\)_2021_Mamun%20Hossain,%20S.%20A.%20A.--\(WRP\).pdf](http://ijat-aatsea.com/pdf/v17_n4_2021_July/14_IJAT_17(4)_2021_Mamun%20Hossain,%20S.%20A.%20A.--(WRP).pdf)
- Mamun Hossain, S. A. A., Lixue, W., Taotao, C., & Zhenhua, L. (2017). Leaf area index assessment for tomato and cucumber growing period under different water treatments. *Plant, Soil and Environment*, 63(10), 461-467. <https://doi.org/10.17221/568/2017-PSE>
- Mamun Hossain, S. A. A., Wang, L., & Liu, H. (2018). Improved greenhouse cucumber production under deficit water and fertilization in Northern China. *International Journal of Agricultural and Biological Engineering*, 11(4), 58-64.
<https://doi.org/10.25165/j.ijabe.20181104.3566>
- Patanè, C., Tringali, S., & Sortino, O. (2011). Effects of deficit irrigation on biomass, yield, water productivity and fruit quality of processing tomato under semi-arid Mediterranean climate conditions. *Scientia Horticulturae*, 129(4), 590-596.
<https://doi.org/10.1016/j.scienta.2011.04.030>
- Pires, R. C. d. M., Furlani, P. R., Ribeiro, R. V., Bodine Junior, D., Sakai, E., Lourenção, A. L., & Torre Neto, A. (2011). Irrigation frequency and substrate volume effects in the growth and yield of tomato plants under greenhouse conditions. *Scientia Agricola*, 68(4), 400-405.
<https://doi.org/10.1590/S0103-90162011000400002>
- Senyigit, U., Kadayifci, A., Ozdemir, F. O., Oz, H., & Atilgan, A. (2011). Effects of different irrigation programs on yield and quality parameters of eggplant (*Solanum melongena* L.) under greenhouse conditions. *African Journal of Biotechnology*, 10(34), 6497-6503.
<https://www.ajol.info/index.php/ajb/article/view/94637>
- Shamshiri, R. R., Jones, J. W., Thorp, K. R., Ahmad, D., Man, H. C., & Taheri, S. (2018). Review of optimum temperature, humidity, and vapour pressure deficit for microclimate evaluation and control in greenhouse cultivation of tomato: a review. *International Agrophysics*, 32(2), 287-302.
<https://doi.org/10.1515/intag-2017-0005>
- Sun, Y., Hu, K., Fan, Z., Wei, Y., Lin, S., & Wang, J. (2013). Simulating the fate of nitrogen and optimizing water and nitrogen management of greenhouse tomato in North China using the EU-Rotate_N model. *Agricultural Water Management*, 128, 72-84.
<https://doi.org/10.1016/j.agwat.2013.06.016>

- Trivedi, P., Schenk, P. M., Wallenstein, M. D., & Singh, B. K. (2017). Tiny Microbes, Big Yields: enhancing food crop production with biological solutions. *Microbial Biotechnology*, 10(5), 999-1003. <https://doi.org/10.1111/1751-7915.12804>
- Van Opstal, J., Droogers, P., Kaune, A., Steduto, P., & Perry, C. (2021). *Guidance on realizing real water savings with crop water productivity interventions* (Vol. 46). Wageningen, FAO and FutureWater. . <https://doi.org/10.4060/cb3844en>
- Wang, X., & Xing, Y. (2017). Evaluation of the effects of irrigation and fertilization on tomato fruit yield and quality: a principal component analysis. *Scientific Reports*, 7(1), 350. <https://doi.org/10.1038/s41598-017-00373-8>
- Xiukang, W., & Yingying, X. (2016). Evaluation of the Effect of Irrigation and Fertilization by Drip Fertigation on Tomato Yield and Water Use Efficiency in Greenhouse. *International Journal of Agronomy*, 2016, 3961903. <https://doi.org/10.1155/2016/3961903>
- Zhai, Y., Yang, Q., & Hou, M. (2015). The Effects of Saline Water Drip Irrigation on Tomato Yield, Quality, and Blossom-End Rot Incidence --- A 3a Case Study in the South of China. *PLoS One*, 10(11), e0142204. <https://doi.org/10.1371/journal.pone.0142204>
- Zhang, H., Khan, A., Tan, D. K. Y., & Luo, H. (2017). Rational Water and Nitrogen Management Improves Root Growth, Increases Yield and Maintains Water Use Efficiency of Cotton under Mulch Drip Irrigation [Original Research]. *Frontiers in Plant Science*, 8. <https://doi.org/10.3389/fpls.2017.00912>
- Zheng, J., Huang, G., Jia, D., Wang, J., Mota, M., Pereira, L. S., . . . Liu, H. (2013). Responses of drip irrigated tomato (*Solanum lycopersicum* L.) yield, quality and water productivity to various soil matric potential thresholds in an arid region of Northwest China. *Agricultural Water Management*, 129, 181-193. <https://doi.org/10.1016/j.agwat.2013.08.001>
- Zhu, J., Liang, Y., Zhu, Y., Hao, W., Lin, X., Wu, X., & Luo, A. (2012). The interactive effects of water and fertilizer on photosynthetic capacity and yield in tomato plants. *Australian Journal of Crop Science*, 6(2), 200-209. http://www.cropj.com/liang_6_2_2012_200_209.pdf