

Unit Commitment-Security Constraints Using the Priority List-Genetic Algorithm Method in the IEEE 6 Bus and IEEE 14 Bus Case Studies

1st Chico Hermanu B.A.
Electrical Engineering Department
Faculty of Engineering
Sebelas Maret University
Surakarta, Indonesia
chico@ft.uns.ac.id

2nd Muhammad Fakhri Erriyanto
Electrical Engineering Department
Faculty of Engineering
Sebelas Maret University
Surakarta, Indonesia
fakhri.erriyanto@gmail.com

3rd Sutrisno
Electrical Engineering Department
Faculty of Engineering
Sebelas Maret University
Surakarta, Indonesia
sutrisno@staff.uns.ac.id

4th Agus Ramelan
Electrical Engineering Department
Faculty of Engineering
Sebelas Maret University
Surakarta, Indonesia
agusramelan@staff.uns.ac.id

Abstract— Unit commitment (UC) is the scheduling of on-off operation of a power plant unit to meet the demand for electrical power over a certain period of time in order to obtain an economical total cost of generation. The PL method is used for scheduling and the AG is optimized using DOE for ED problems. The results obtained from the research that there are still improvements in the calculation of ED problems using load flow constraints and can be corrected. The results of the comparison of the total percentage cost of IEEE 6 buses used in ED problems without considering the load flow constraints with those considering this problem amounted to 26.30%. The result of the comparison of the total percentage cost of IEEE 14 buses used in ED problems without considering load flow constraints with those considering this problem is 11.55%. The load flow calculation using Newton-Raphson uses a smaller number of iterations and a shorter time than Gauss-Seidel.

Keywords— unit commitment, genetic algorithm, priority list, design of experiment, load flow constraints, economic dispatch.

I. INTRODUCTION

In line with the increasing population and economic growth, domestic demand for electrical energy continues to increase from year to year. With the increasing demand for electrical energy, the supply of electricity by generators maintained by government and private companies must also increase. The electric power system is not supplied by just one generator. In the case of electric power systems, the total load on the system will be higher during the day and at dusk when industrial loads are high, lights are on, etc., and low during late at night and early morning when most people are not active [1]. Why not easily fit in enough units to cover the maximum load and let it run?

Therefore a program is carried out that provides a schedule to minimize operating costs without reducing the efficiency of a system, namely the unit commitment (UC). UC is a system where the generator makes scheduling for its generator to do power outages and livelihoods [2]. This UC aims to get the maximum efficiency so that energy can be channeled properly. This UC also aims to minimize generation costs and fuel costs by not violating the restrictions imposed by a system.

In this UC development, there have been various optimization methods to solve this UC problem. Initially, the method used is a conventional and simple method in the form

of conventional iterations such as integer programming, dynamic programming, priority list (PL), lagrangian relaxation, etc. [3] [4] [5]. As technology advances, this method is often trapped in local optimal and various other optimization methods are introduced in the form of metaheuristics such as genetic algorithm (AG), fuzzy logic, ant colony, etc. [6]. This method uses multi-searching points to find an optimal solution, so that the output obtained can be close to the optimal point [7].

In this study, the IEEE (Institute of Electrical and Electronic Engineering) case 6 and 14 bus standard test data will be used. The unit commitment issue will be divided into two parts, namely the problem of scheduling the generating unit (on off unit) and the problem of economic dispatch (ED). In the second case, it will be divided into two, namely UC problems by considering load flow constraints with UC problems without considering load flow constraints.

In scheduling problems, the PL method is used, because this method is simple and fast for the solution obtained. In the ED problem, the method used in this problem is genetic algorithm (AG), because in the search for a solution, AG will work without requiring exact information so that the solution obtained can approach the global optimal solution. The parameter values generated by the AG will be optimized by the design of experiment (DOE) method.

A. Notations

S_{oi}	= cold start-up cost of the i generator unit
$D_i, E-i$	= the coefficient of start-up cost of the i generating unit
T_{offi}	= offline time of the i generating unit (hours)
T_{downi}	= minimum time offline for the i generator to be restarted (hour)
PL_t	= total power losses supplied at time t
SR_i	= spinning reserve that must be fulfilled at time t
P_{maxi}	= the maximum limit of active power that can be generated by the unit generator i
P_{mini}	= the minimum limit of active power that can be generated by the unit generator i
T_{ion}	= minimum up time of the i generating unit
T_{ioff}	= minimum down time of the i generating unit
$X_{ion}(t)$	= life time from the i generating unit to t -time
$X_{ioff}(t)$	= time off from the i generating unit to time t

Q_{mini}	= minimum limit of reactive power by the i unit
Q_{maxi}	= maximum limit of reactive power by the i unit
Q_{it}	= reactive power by the i unit at time t
PL_{tk}	= power delivered to the k channel at the t -time,
PL_{maxk}	= maximum power that can be delivered on the k - channel
V_{minb}	= the minimum limit for the voltage value on the b -bus
V_{maxb}	= the maximum limit of the voltage value on the b bus
V_{tb}	= bus value of the b - bus at time t
t_{mink}	=the minimum limit of the transformer tap value on the k -channel
t_{maxk}	=the maximum limit of the transformer tap value on the k -line
ttk	=the value of the transformer tap on the b channel at time t
$FLAPC$	= full load average production cost
FF	= fitness function
FP_v	= active power penalty function
FP_Q	= reactive power penalty function
FP_{psw}	= swing bus power penalty function
FPP_{sal}	= line voltage penalty function

B. Unit Commitment

Basically, UC problematics can be formulated as large-scale non-linear optimization, integers with binary and continuous variables. UC is defined as a function of the on / off schedule of the generating unit in order to minimize the total production costs such as the balance of the power system [8]. The formulation of the problem is divided into two broad outline, namely:

- Objective Functions
 - a. Fuel Function
 - b. Start-up Cost Function
- Constraints function
 - a. Unit Constraints
 - b. System Constraints
 - c. Security Constraints

1. Objective Function

To solve problems on UC, the objective function must first be defined in order to have a goal. The objective function is the total cost of generating all existing generating units during a certain time span [8]. It can be defined as follows,

$$\sum_{t=1}^T \sum_{i=1}^N [F_i(P_{it}^t) + S_{i,t}] U_i^t = F(P_{it}^t, U_i^t)$$

The objective function (1) includes two cost formula functions the first is the fuel function which is defined as follows,

$$F_i(P_{it}) = \sum_{i=1}^N [A_i + B_i P_{it} + C_i P_{it}^2]$$

The fuel cost function is a function that shows how much it costs to generate power in each generating unit. The second is a start-up function which is defined as follows [9],

$$S_{it} = \left(S_{oi} \left(1 - D_i \exp \left(-\frac{T_{offi}}{T_{downi}} \right) \right) \right) + E_i$$

The start-up cost will be expensive if the unit is turned on in cold start, and the cheaper it is when the unit is restarted

when it has just been turned off which is known as hot start unit [9].

2. Constraints

Restrains or constraints are divided into three, the first is a system constraints which consists of a balance of power to the system connected to the transmission line which has the following functions,

$$\sum_{i=1}^N P_{it} = P_{Dt} + P_{Lt}$$

Spinning reserve which has the following functions [10],

$$\sum_{i=1}^N U_{it} (P_{maxi}) \geq P_{Dt} + SR_t, 1 \leq t \leq T$$

The second is unit constraints, unit constraints include minimum and maximum power limits, minimum up / down-time, and initial conditions for each generating unit [11]. the minimum and maximum functions of each generating unit are as follows [12],

$$P_{min_i} \leq P_{it} \leq P_{max_i}, P_{it} \in R$$

The function of the minimum up / down time for each generating unit is as follows,

$$\begin{aligned} T_i^{on} &\leq X_i^{on}(t) \\ T_i^{off} &\leq X_i^{off}(t) \end{aligned}$$

The last one is security constraints, which consists of the limits on the channel which include the upper and lower limits of reactive power which have the following functions [13],

$$Q_{min_i} \leq Q_{it} \leq Q_{max_i}$$

Then the active power limit on the channel which has the following function equation [9],

$$PL_k^t \leq PL_{max_k}$$

Then there is the voltage value for each bus. Therefore we need a function of the maximum value and minimum value of the voltage on the bus with the following function equation [14],

$$V_{min_b} \leq V_b^t \leq V_{max_b}$$

And the last is the value of the transformer tap on the transmission line which has the following equation function [14],

$$t_{min_k} \leq t_k^t \leq t_{max_k}$$

The constraints above are the limitations used in the transmission system model that is applied.

II. METHOD

In completing this UC settlement, there are two problems that will be carried out to solve the problem, namely scheduling problems and economic dispatch (ED) problems. Scheduling problems will be solved using the priority list method, while ED problems will be solved using genetic algorithms. The flow of the method explanation can be seen in detail like the flow chart below,

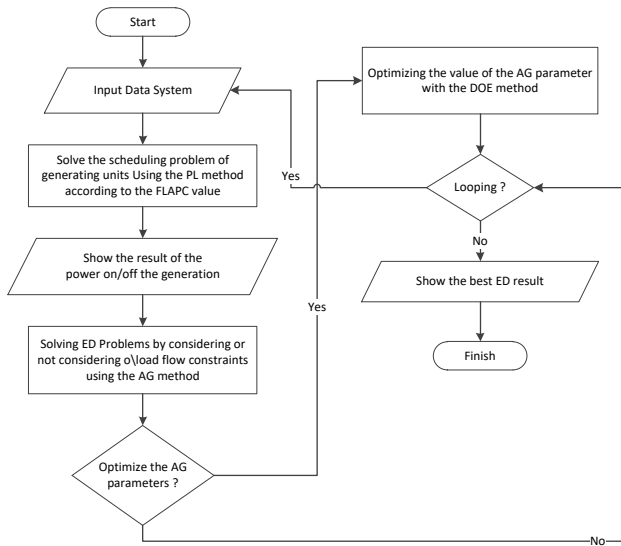

Figure 1. UC flowchart

1. The simulation will be carried out with two scenarios which will be compared on the results, namely UC by considering load flow constraints and UC without considering load flow constraints. *Scheduling Problems*

To solve the UC problem, first a generator scheduling will be carried out using the PL method. In this section, scheduling of generating units will determine the conditions of on / off a generating unit in the system by taking into account the constraints applied. The aim of this is to minimize the start-up costs of the generating unit. This problem depends on the value of the full load average production cost (FLAPC) which has the following function equation,

$$FLAPC = F_i(P_{maks.i})/P_{maks.i}$$

2. The FLAPC value will determine which generating unit will be turned on to meet the existing load and meet the MUT and MDT constraints on the system. *Economic Dispatch Problems*

ED problems will be solved using the AG method with real coding. The variables used in general are active power, voltage and transformer taps. To solve ED problems, scheduling problems must first be done. As explained above, the scheduling will be completed using the calculated FLAPC value. After getting the results from scheduling the generating unit, one of the results will be selected to be the initial chromosome of the GA which has a value of 1 or 0 indicating the condition of the generating unit (0 indicates that the unit is off and 1 is on).

The representation of AG is a three-dimensional matrix with rows representing the scheduling time to the nth time, the column representing the number of generating units to the nth unit and the contents of the rows and columns consisting of 1 and 0 which are genes. for more details, can be seen in the image below [15],

Generator	Time				
	1	2	3	...	N
G1	1	1	0	...	1
G2	1	1	0	...	0
G3	0	0	1	...	0
...
GN	0	1	0	...	0

Generator	Time				
	1	2	3	...	N
G1	1	1	1	...	1
G2	1	0	0	...	0
G3	1	1	0	...	0
...
GN	0	1	0	...	0

Generator	Time				
	1	2	3	...	N
G1	1	1	1	...	1
G2	1	1	1	...	1
G3	0	1	0	...	0
...
GN	0	0	1	...	0

Generator	Time				
	1	2	3	...	N
G1	1	1	1	...	1
G2	1	1	1	...	0
G3	0	0	1	...	1
...
GN	0	1	1	...	0

Figure 2. Representation of AG

A random population will be created from the scheduling results in order to find the best individual in the parent selection process. This population will be randomly generated by making scheduling improvements to meet MUT / MDT limits before proceeding to the economic dispatch process. If it is in accordance with the given limits, then the individual will be given a penalty value and will enter the selection process through the fitness function that has been defined below,

$$FF = \frac{1}{a + F_i(P_{it}) + FP_v + FP_Q + FP_{psw} + FP_{psal}}$$

The fitness function used is inversely proportional to the fitness formula given, this function has information that the higher the fitness value of a chromosome, the chromosome will have a higher chance of being selected as an individual parent. After the fitness value of each chromosome is known, it will be evaluated which one has the greatest fitness value and will be used as the parent to proceed to the reproduction process of the genetic algorithm.

A. Parameter Optimization Using DOE Method

To optimize the parameters, the method of design of experiment 4 factors 2 levels is used which refers to the Taguchi's Table. Which can be seen in the table below,

TABLE 1. THE EXPERIMENTAL TESTING METHOD FOR DOE 4 FACTORS 2 LEVELS

	Symbol				Price			
	A	B	C	D	Trial-1	Trial-2	Trial-3	Rata2
1	-1	-1	-1	-1	a1	a2	a3	a
2	-1	-1	-1	1	b1	b2	b3	b
3	-1	-1	1	1	c1	c2	c3	c
4	-1	1	1	1	d1	d2	d3	d
5	-1	1	-1	-1	e1	e2	e3	e
6	1	1	-1	1	f1	f2	f3	f
7	-1	1	1	1	g1	g2	g3	g
8	-1	1	1	-1	h1	h2	h3	h
9	1	-1	1	1	i1	i2	i3	i
10	1	-1	1	-1	j1	j2	j3	j
11	1	1	-1	1	k1	k2	k3	k
12	1	1	1	-1	l1	l2	l3	l

There are 12 type of combination and 3 times trial for each hour of the simulation. Symbol 1 on the DOE table indicates the maximum limit, and symbol -1 on the DOE table indicates the minimum. The simulation will be carried out 3 times to get the average cost for each combination. The lowest total cost result is the optimal solution.

III. RESULT AND ANALYSIS

Simulations will be carried out on two systems, namely IEEE 6 bus and IEEE 14 bus with two scenarios, namely UC by considering load flow constraints with UC without considering load flow constraints, the following is a graphical result of UC settlement.

A. IEEE 6 Bus System

The IEEE 6 bus system consists of 3 generator units, 7 transmission lines, 6 buses, 3 load units, and 2 tap transformer units. The results of the simulation can be seen in the table as follows,

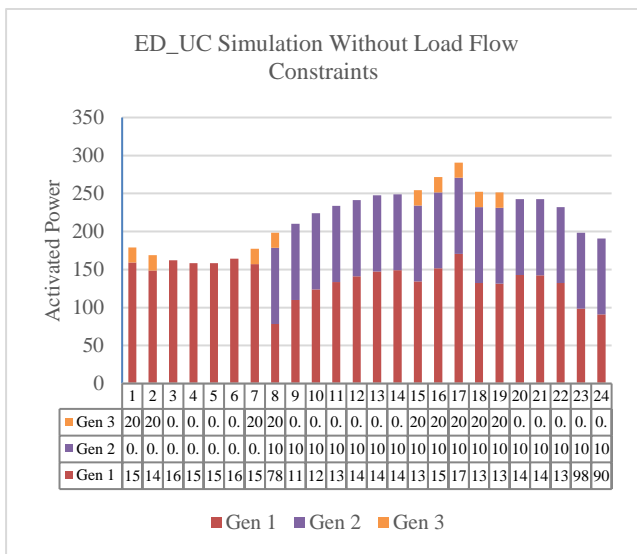

Figure 3. UC IEEE 6 bus simulation without load flow constraints

In the picture above, you can see the results of scheduling problems and ED for UC without considering load flow constraints, the parameters used are not based on DOE, so for the population size is 50, the maximum total is 200 generations, the probability value of crossing over is 0.9, and the value mutation probability 0.12. A value of 0 on the generator indicates that the generator is off. Whereas a value of more than 0 indicates that the generator is running and producing power as in the table above.

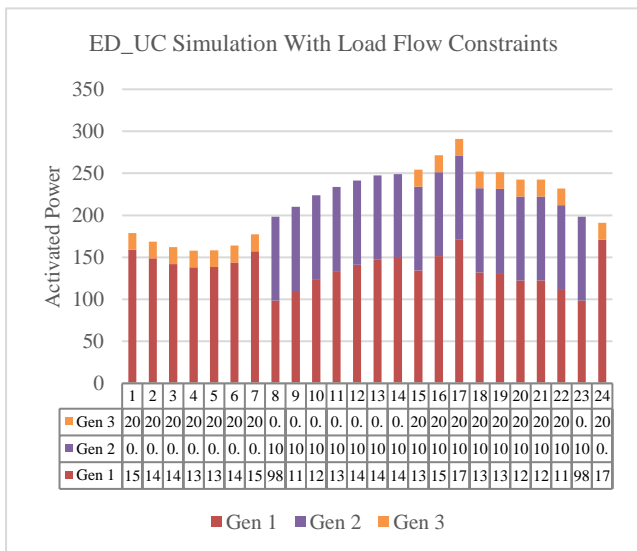

Figure 4. UC IEEE 6 bus simulation with load flow constraints

TABLE 2. RESULT OF SCHEDULING AND ED UC IEEE 6 BUS WITH LOAD FLOW CONSTRAINTS

Hour	Condition (1 and 0)			Power (MW)		
	Gen 1	Gen 2	Gen 3	Gen 1	Gen 2	Gen 3
1	1	0	1	159.05	0.0	20.0
2	1	0	1	148.76	0.0	20.0
3	1	0	1	142.13	0.0	20.0
4	1	0	1	138.10	0.0	20.0
5	1	0	1	138.43	0.0	20.0
6	1	0	1	143.98	0.0	20.0
7	1	0	1	157.21	0.0	20.0
8	1	1	0	98.54	100.0	0.0
9	1	1	0	110.03	100.0	0.0
10	1	1	0	123.96	100.0	0.0
11	1	1	0	133.65	100.0	0.0
12	1	1	0	141.31	100.0	0.0
13	1	1	0	147.57	100.0	0.0

14	1	1	0	149.01	100.0	0.0
15	1	1	1	134.31	100.0	20.0
16	1	1	1	151.46	100.0	20.0
17	1	1	1	170.79	100.0	20.0
18	1	1	1	132.15	100.0	20.0
19	1	1	1	131.35	100.0	20.0
20	1	1	1	122.52	100.0	20.0
21	1	1	1	122.47	100.0	20.0
22	1	1	1	112.06	100.0	20.0
23	1	1	0	98.40	100.0	0.0
24	1	0	1	171.11	0.0	20.0

TABLE 3. RESULT OF DOE 4 FACTORS 2 LEVEL FOR CASE IEEE 6 BUS

No	PARAMETER				Cost Trial-1 (\$)	Cost Trial-2 (\$)	Cost Trial-3 (\$)	Cost Average (\$)
	X1	X2	X3	X4				
1	-1	-1	-1	-1	47.438,15	47.436,48	47.437,59	47.437,41
2	-1	-1	-1	1	47.428,38	47.427,39	47.429,37	47.428,38
3	-1	-1	1	1	47.429,21	47.424,38	47.429,62	47.427,74
4	-1	1	1	1	47.426,80	47.427,30	47.429,63	47.427,91
5	-1	1	-1	-1	47.438,33	47.428,81	47.429,92	47.432,35
6	1	1	-1	1	47.422,94	47.428,21	47.427,60	47.426,25
7	-1	1	1	1	47.427,64	47.425,59	47.431,51	47.428,25
8	-1	1	1	-1	47.436,93	47.427,83	47.436,42	47.433,73
9	1	-1	1	1	47.429,47	47.423,91	47.426,98	47.426,78
10	1	-1	1	-1	47.428,21	47.428,28	47.435,35	47.430,61
11	1	1	-1	1	47.422,41	47.422,32	47.428,13	47.424,29
12	1	1	1	-1	47.428,37	47.424,14	47.428,01	47.426,84

In the Figure 4 and table 2, you can see the results of scheduling and ED problems for UC by considering load flow constraints, the best parameters used are based on DOE optimization that labeled green (table 3), so for the population size (X1) is 50, the total maximum generation (X2) is 200, the crossover probability value (X3) is 0.5, and the value mutation probability (X4) 0.12.

Table 3 above shows the cost of each combination of DOE parameters, three times the trial cost and the average cost. The results obtained will then be used to find the predictive equation function using Microsoft Excel 2010 software. After being processed in the form of Microsoft Excel 2010, a prediction equation is obtained as follows,

$$R = 47.431,09 - 1,316 - 0,824X_2 + 0,2264X_3 - 2,219X_4$$

To get the best DOE parameter value between 1 and -1, the value of the parameter will be entered into the prediction function equation. The value of the equation function will be the minimum value at the value of X1 = 1, X2 = 1, X3 = -1, and X4 = 1 with a value of R = \$ 47,426.51. This combination value can be seen and validated then you will get three times the trial cost and the average cost in Table 4.

After three trials, the total production costs used in the IEEE 6 bus system are as follows,

TABLE 2. COMPARISON RESULTS OF THE TOTAL COST OF UC IEEE 6 BUSES

Method	UC with load flow constraints	UC without load flow constraints
Fuel cost	\$47.233,73	\$34.759,81
Start-up cost	\$200	\$200
Total cost	\$47.433,73	\$34.959,81

It can be seen in the table above, that the results of UC with load flow constraints are more expensive than UC without considering load flow constraints. Although the total cost of the UC by considering load flow constraints is more expensive than those that are not, this UC solution is arguably stable and efficient and feasible to be used as a solution to meet the load of this UC problem, because there are no violations of the limits used. The percentage ratio of the total cost between the two is,

$$\left(\frac{\$47.433,73 - \$34.959,81}{\$47.433,73} \right) \times 100\% = 26,30 \%$$

B. IEEE 14 Bus System

The IEEE 14 bus system consists of 5 generator units, 20 transmission lines, 14 buses, 11 load units, and 3 tap transformer units. The results of the simulation can be seen in the table as follows,

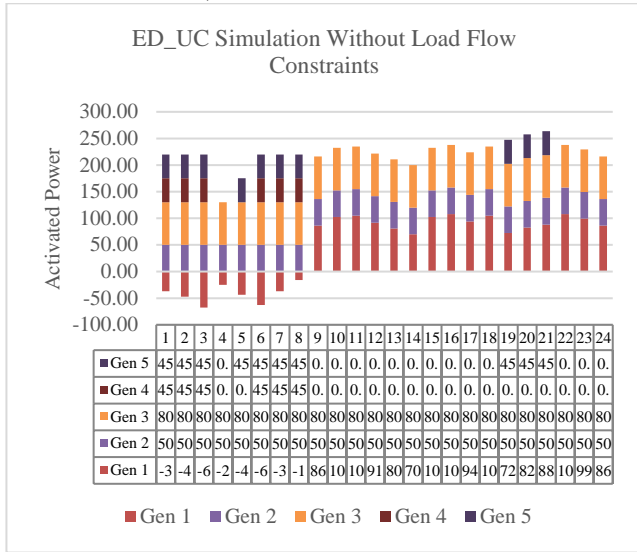

Figure 5. UC IEEE 14 bus simulation without load flow constraints

In the picture above, you can see the results of scheduling problems and ED for UC without considering load flow constraints, the parameters used are not based on DOE, so for the population size is 50, the maximum total is 200 generations, the probability value of crossing over is 0.9, and the value mutation probability 0.12. A value of 0 on the generator indicates that the generator is off. Whereas a value of more than 0 indicates that the generator is running and producing power as in the table above. In the simulation results above, it can be seen that the generating unit 1 from the 1st hour to the 8th hour is still in the negative domain, therefore it is necessary to improve the scheduling and increase the limitation to improve this.

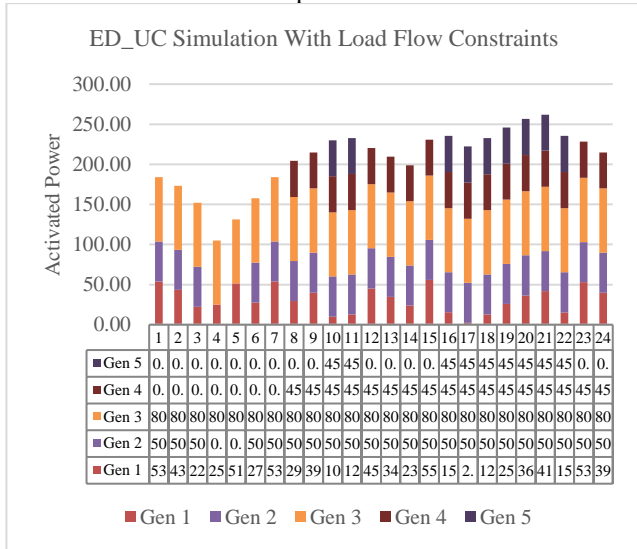

Figure 6. Simulation of UC IEEE 14 buses with load flow constraints

TABLE 4. RESULT OF SCHEDULING AND ED UC IEEE 14 BUS WITH LOAD FLOW CONSTRAINTS

Hour	Condition (1 and 0)					Power (MW)				
	Gen 1	Gen 2	Gen 3	Gen 4	Gen 5	Gen 1	Gen 2	Gen 3	Gen 4	Gen 5
1	1	1	0	0	1	88.5	50.0	0.0	0.0	45.0
2	1	1	0	0	1	77.8	50.0	0.0	0.0	45.0

3	1	1	0	0	0	102.6	50.0	0.0	0.0	0.0
4	1	1	0	0	0	54.6	50.0	0.0	0.0	0.0
5	1	1	0	0	0	81.2	50.0	0.0	0.0	0.0
6	1	1	0	0	0	107.9	50.0	0.0	0.0	0.0
7	1	1	1	0	0	54.0	50.0	80.0	0.0	0.0
8	1	1	1	1	0	29.3	50.0	80.0	45.0	0.0
9	1	1	1	1	0	39.8	50.0	80.0	45.0	0.0
10	1	1	1	1	0	55.8	50.0	80.0	45.0	0.0
11	1	1	1	1	0	58.5	50.0	80.0	45.0	0.0
12	1	1	1	1	0	45.1	50.0	80.0	45.0	0.0
13	1	1	1	1	0	34.6	50.0	80.0	45.0	0.0
14	1	1	1	1	0	23.9	50.0	80.0	45.0	0.0
15	1	1	1	1	0	88.5	50.0	0.0	0.0	45.0
16	1	1	1	1	0	55.8	50.0	80.0	45.0	0.0
17	1	1	1	1	0	61.1	50.0	80.0	45.0	45.0
18	1	1	1	1	1	47.8	50.0	80.0	45.0	45.0
19	1	1	1	1	1	12.7	50.0	80.0	45.0	45.0
20	1	1	1	1	1	25.9	50.0	80.0	45.0	45.0
21	1	1	1	1	1	36.5	50.0	80.0	45.0	45.0
22	1	1	1	1	1	41.9	50.0	80.0	45.0	45.0
23	1	1	1	1	1	15.3	50.0	80.0	45.0	45.0
24	1	1	1	1	0	7.4	50.0	80.0	45.0	45.0

TABLE 5. RESULT OF DOE 4 FACTORS 2 LEVEL FOR CASE IEEE 6 BUS

	PARAMETER				Cost Trial-1 (\$)	Cost Trial-2 (\$)	Cost Trial-3 (\$)	Cost Average (\$)
	A	B	C	D				
1	-1	-1	-1	-1	57.847,32	58.043,13	59.882,34	58.590,93
2	-1	-1	-1	1	54.767,96	58.831,19	54.535,55	56.044,90
3	-1	-1	1	1	53.427,70	57.848,92	55.139,98	55.472,20
4	-1	1	1	1	55.930,49	53.728,51	55.924,84	55.194,61
5	-1	1	-1	-1	56.656,01	53.858,45	55.245,59	55.253,35
6	1	1	-1	1	55.712,29	55.089,64	55.821,08	55.541,00
7	-1	1	1	1	51.813,80	58.748,82	55.087,63	55.216,75
8	-1	1	1	-1	58.905,88	53.545,95	53.429,75	55.293,86
9	1	-1	1	1	52.995,49	52.961,36	52.208,52	52.721,79
10	1	-1	1	-1	54.474,00	50.869,06	53.578,47	52.973,84
11	1	1	-1	1	51.310,07	51.237,69	56.200,43	52.916,06
12	1	1	1	-1	52.608,18	52.705,13	51.312,45	52.208,59

In the Figure 6 and table 4, you can see the results of scheduling and ED problems for UC by considering load flow constraints, the best parameters used are based on DOE optimization that labeled green (table 3), so for the population size (X1) is 50, the total maximum generation (X2) is 200, the crossover probability value (X3) is 0.9, and the value mutation probability (X4) 0.04.

Table 5 above shows the cost of each combination of DOE parameters, three times the trial cost and the average cost. The results obtained will then be used to find the predictive equation function using Microsoft Excel 2010 software. After being processed in the form of Microsoft Excel 2010, a prediction equation is obtained as follows,

$$R = 54.936,44 - 854,32X_1 - 182,99X_2 - 1.239,69X_3 + 133,05X_4$$

To get the best DOE parameter value between 1 and -1, the value of the parameter will be entered into the prediction function equation in (4.4). the value of the equation function will be the minimum value at the value of X1 = 1, X2 = 1, X3 = 1, and X4 = -1 with a value of R = \$ 52,526.39. This combination value can be seen and validated then you will get three times the trial cost and the average cost in Table 5.

After three trials, the total production costs used in the IEEE 6 bus system are as follows,

TABLE 3. COMPARISON RESULTS OF THE TOTAL COST OF UC IEEE 14 BUSES

Method	UC with load flow constraints	UC without load flow constraints
Fuel cost	\$58.390,97	\$51.623,66
Start-up cost	\$200	\$200
Total cost	\$58.59,97	\$51.823,66

It can be seen in the table above, that the results of UC with load flow constraints are more expensive than UC without considering load flow constraints. Although the total cost of the UC by considering load flow constraints is more

expensive than those that are not, this UC solution is arguably stable and efficient and feasible to be used as a solution to meet the load of this UC problem, because there are no violations of the limits used. The percentage ratio of the total cost between the two is,

$$\left(\frac{\$58.590,97 - \$51.823,66}{\$58.590,97} \right) \times 100\% = 11,55 \%$$

IV. CONCLUSIONS

The PL method and the AG method can be used to solve UC problems with or not considering load flow constraints on the IEEE 6 bus and IEEE 14 bus systems by optimizing the AG parameters using DOE for UC by considering load flow constraints. Comparison of the total cost for a UC system taking into account the load flow constraints of the IEEE 6 bus is 26.30% more expensive and for the IEEE 14 bus system it is 11.55% more expensive than the UC without the use of constraints.

Although the UC IEEE 6 and 14 bus systems using constraints are more expensive, they can meet the load requirements without breaking any restrictions and are more feasible to use.

REFERENCE

[1] Wood, A.J. & Wollenberg, B.F., 1996. *Power Generation, Operation, and Control, Second Edition*. New York: John Wiley & Sons.

[2] Chefai Dhifaoui, Ismail Marouani, Hsan Hadj Abdallah, "Unit Commitment Problem with Wind and Solar Energy Considering Emission Reduction using Dynamic Programming", *International Journal of Advanced Science and Technology*, 2020. 29(05), pp. 4152 - 4162.

[3] Christiansen, J.C..D.C.A.&.B.J.P., "An Approach to Solve the Unit Commitment Problem Using Genetic Algorithm". In *IEEE Power Engineering Society Summer Meeting*, 2000.

[4] Padhy, N.P., "Unit Commitment-A bibliographical survey". *IEEE Transactions on Power Systems*, 2004. 19(2), pp.1196 - 1205.

[5] Tingfang, Y. & Ting, T.O., "Methodological Priority List for Unit Commitment Problem". *International Conference on Computer Science and Software Engineering*, 2008. 1, pp.176-79.

[6] Dasgupta, D. & McGregor, D.R., "Thermal unit commitment using genetic algorithms. *IEE Proceedings-Generation, Transmission and Distribution*, 1994. 141(5), pp.459 - 465.

[7] Momoh, J.A., 2001. *Electric Power System Applications of Optimization*. New York: Marcel Dekker, Inc.

[8] Adiwena Danar, dkk. "Unit Commitment Mempertimbangkan Stabilitas Tegangan dengan Metode Binary Particle Swarm Optimization (BPSO)", *Jurusan Teknik Elektro, Institut Sepuluh Nopember, Surabaya*, pp. 289-294, 2016.

[9] Budi Mulyawan Arief, "Unit Commitment Menggunakan Metode Hibrid Priority List dan Algoritma Genetika Dengan Mempertimbangkan Load Flow Constraints", *Skripsi Universitas Gajahmada*, 2013.

[10] Sarijaya, P. Hadi Sasongko, Rizki W. Daniar. "Unit Commitment dengan Kekangan Keandalan Menggunakan Algoritme Genetika Mempertimbangkan Ketidakpastian Beban", pp. 341-347, 2016.

[11] F. N. Budiman, Sarjiya, dan M. Isnaeni, "Penjadwalan Unit Pembangkit Termal dengan Memperhitungkan Kekangan Emisi Lingkungan dan Ketidakpastian Sistem", *Skripsi Universitas Gadjah Mada*, 2009.

[12] J. H. Van Sickle, K. Y. Lee, and J. S. Heo, "Differential Evolution and Its Applications to Power Plant Control," *International Conference on Intellegent Systems Applications to Power Systems*, no. 2, pp. 560-565, 2007.

[13] P. Kundur, J. Paserba, V. Ajarapu, G. Andersson, A. Bose, C. Canizares, N. Hatziaegyriou, D. Hill, A. Stankovic, C. Taylor, T. Van Cutsem, and V. Vittal, "Definition and classification of power system stability", *IEEE Trans. on Power Syst.*, Vol. 19, No. 4, 2004, pp. 1387-1401.

[14] Capitanescu Florin, "Assessing Reactive Power Reserves with Respect to Operating Constraints and Voltage Stability", *University of Liedege*, 2003.

[15] Sarjiya, A. B. Mulyawan and A. Sudiarso, "Optimal solution of reliability constrained unit commitment using hybrid genetic algorithm-priority list method," *2014 6th International Conference on Information Technology and Electrical Engineering (ICITEE)*, Yogyakarta, Indonesia, 2014, pp. 1-6.

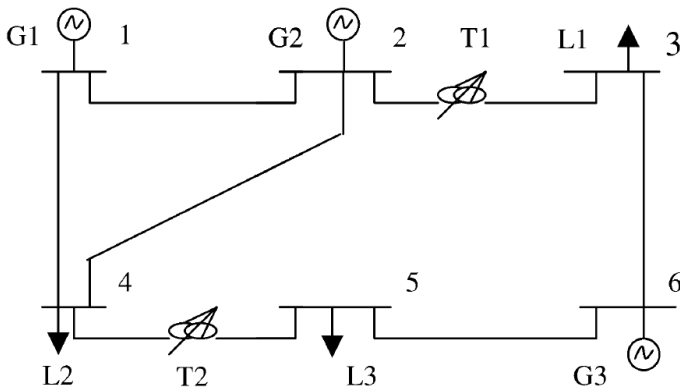

Figure 7. Single line diagram case study IEEE 6 bus (Fu et al., 2005)

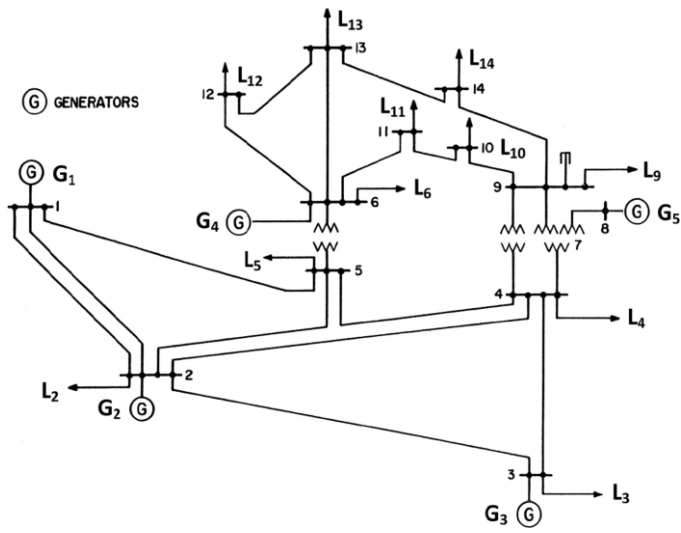

Figure 8. Single line diagram case study IEEE 14 bus (P. Dey, et al 2018)